

ERGO-HANDLE CART - DH-PH4-2472-3

APPROX WEIGHT: 353.37 lbs.
 DOES NOT INCLUDE WEIGHT OF POWER OR PACKAGING!!!

*** ANY ADDITIONS, DELETIONS, OR OMISSIONS MUST BE CORRECTED ON THIS DRAWING AS THIS DRAWING WILL BE CONSIDERED ALL INCLUSIVE ***
 ALL GRAPHICS PROVIDED ARE FOR REFERENCE ONLY. IF CERTAIN DIMENSIONS ARE CRITICAL PLEASE VERIFY THOSE DIMENSIONS WITH YOUR SALESPERSON

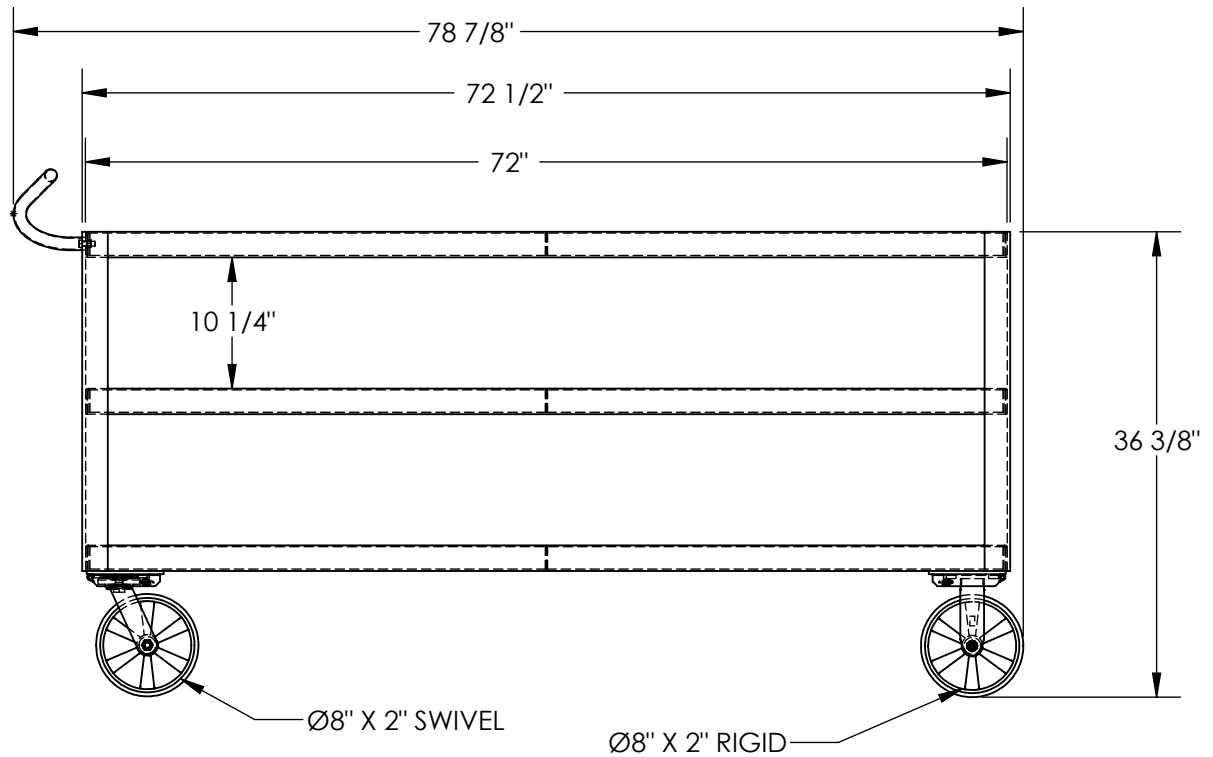
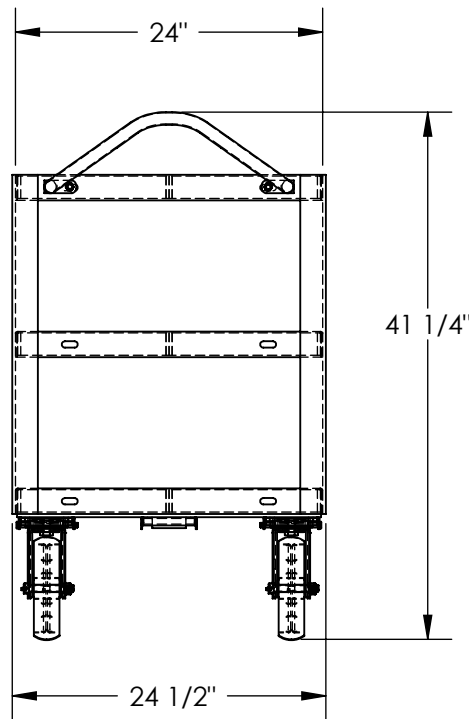

DIMENSION TOLERANCE ± 1/4"

STANDARD FEATURES

MODEL NUMBER IS DH-PH4-2472-3
 MAXIMUM CART CAPACITY IS 4,000 LBS.
 MAXIMUM SHELF CAPACITY IS 2,000 LBS.
 NOT TO EXCEED MAXIMUM CAPACITY OF THE CART
 OVERALL WIDTH IS: 24 1/2"
 USABLE WIDTH IS: 24"
 OVERALL LENGTH IS: 78 7/8"
 USABLE LENGTH IS: 72"
 OVERALL HEIGHT IS: 41 1/4"
 SHELF CLEARANCE IS: 10 1/4"
 2 RIGID 8" x 2" GLASS FILLED NYLON CASTERS
 2 SWIVEL 8" x 2" GLASS FILLED NYLON CASTERS
 STEEL CONSTRUCTION
 TOUGH BAKED IN POWDER COATED BLUE FINISH

SPECIAL FEATURES

NONE

APPROVAL

I, THE UNDERSIGNED, AGREE THAT THE PRODUCT AS REPRESENTED SATISFIES DESIGN AND DIMENSION REQUIREMENTS. I ALSO ACKNOWLEDGE MY DUTY TO CONFIRM PRODUCT AND INSTALLATION COMPLIANCE WITH ALL APPLICABLE FEDERAL, STATE AND LOCAL REGULATIONS AND STANDARDS.
UNITS REQUIRING APPROVAL DRAWINGS OR MODIFIED ARE NON-RETURNABLE
 As drawn As marked

Signed: _____ Date: _____

Printed Name: _____

LEAD TIME WILL START UPON RECEIPT OF SIGNED APPROVAL DRAWING

DISTRIBUTOR'S NAME:		P.O.#
VESTIL MANUFACTURING		X
DRAWN BY: T.MOORE		W.O.#
DATE: 08/20/2010		X
REFERENCE: X	SCALE: 1:15	SALES: X
QUOTED LEAD TIME: X	QUOTE #	FILE NAME:
	X	33-007-082